



DATA SHEET

revision date
22.12.2023

product code

20.30.01.01

Trolley for a mobile cleaning point - big



304



MATERIAL	Stainless Steel
WEIGHT	33 kg
MAX. DIMENSIONS (WxHxD)	76 x 123 x 119 cm
MAX. LOAD	250 kg
PACKAGE DIMENSIONS (WxHxD)	-



RYSUNEK TECHNICZNY Z WYMIARAMI

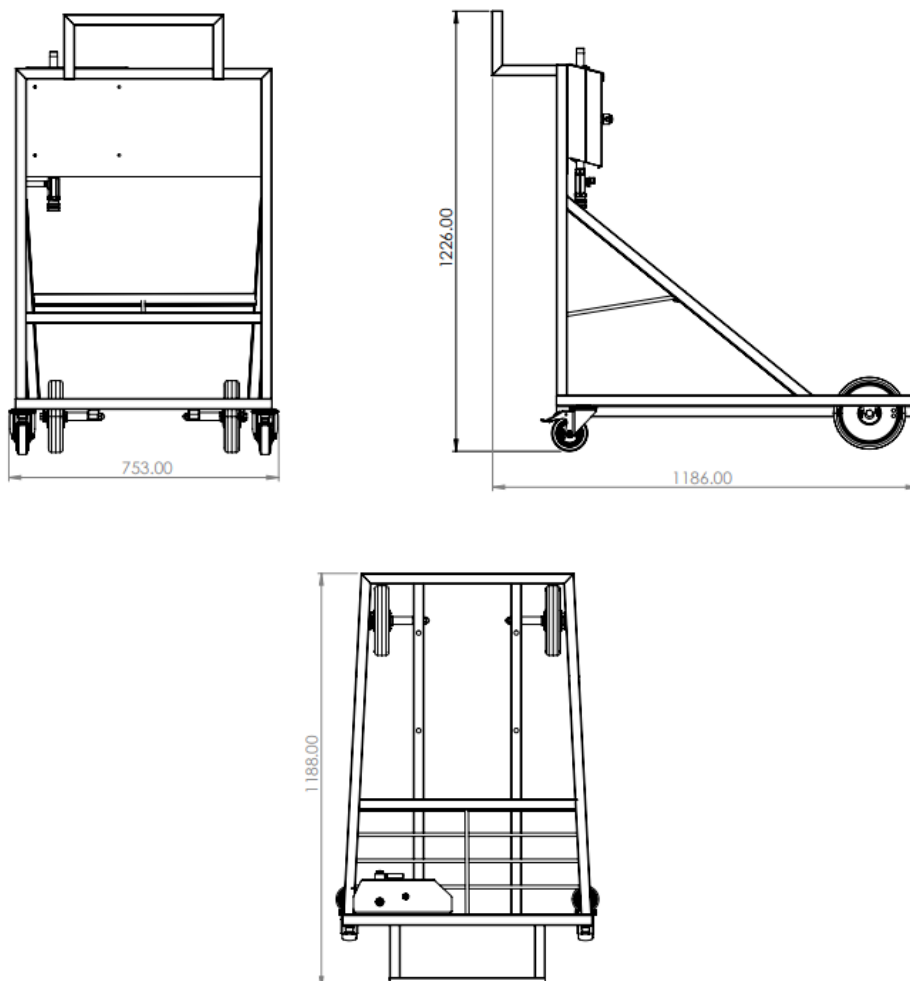

- Solid and durable construction from stainless steel.
- Two large wheels and two swivel wheels with locks that allow stabilization in the workplace.
- Handle to hold.
- A place for chemical canisters.
- Possibility of mounting the stamps train.
- It is equipped with bumpers that protects against damage to walls or devices.
- Laser marking available on request.
- Possibility of making the trolley in a different size on special order.
- Additional accessories: Satellite Clean FOAM PLUS/PLUSi, Automatic hose reel, ULTRA HYGIENIC® Antimicrobial Hose, ULTRA HYGIENIC® Antimicrobial connection hose, ULTRA HYGIENIC® ball valve 1/2" with stainless steel protection and ULTRA HYGIENIC® Antimicrobial female quick coupling Blue and stamp train.